

Stage:	01 - HANDGUN
Targets:	12 IPSC Targets.
Number of rounds to be scored:	24
Start Position:	Standing, inside the Area.
Start:	audible signal.
Procedure:	At the start signal engage targets from within designated area .

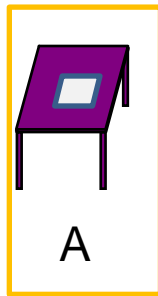

Stage:	02- HANDGUN
Targets:	1 IPSC Popper and 7 IPSC Metal Plates.
Number of rounds to be scored:	8
Gun ready condition:	Chamber and magwell empty flat in the mark on the table.
Start Position:	Standing inside the area , hands above the shoulders.
Start:	audible signal.
Procedure:	At the start signal engage targets from within designated area .

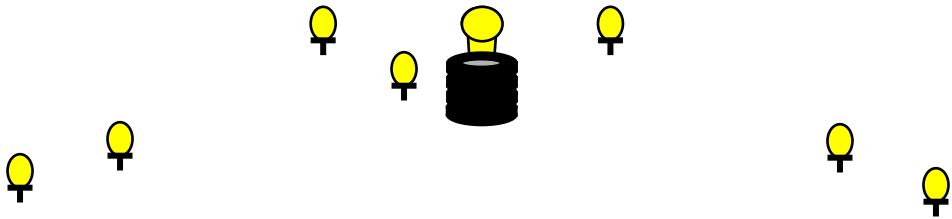
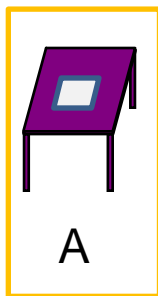
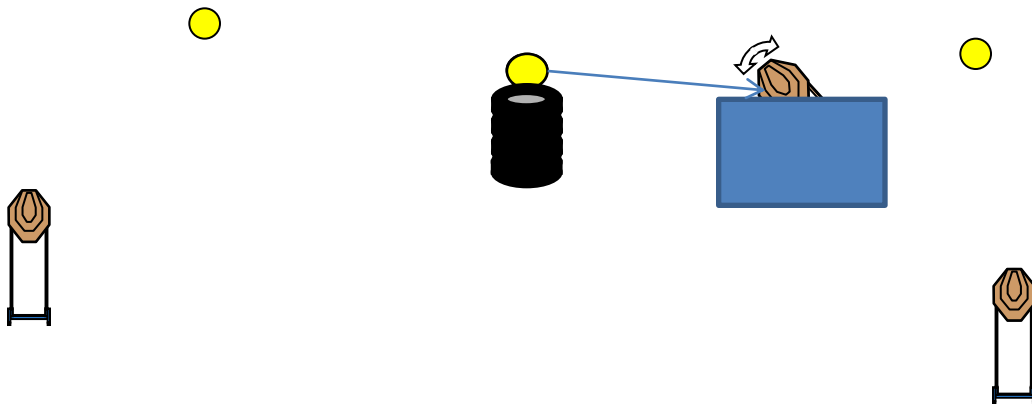

Stage:	03- HANDGUN
Targets:	3 IPSC Targets, 1 IPSC Popper and 2 IPSC Metal Plates.
Number of rounds to be scored:	9
Gun ready condition:	Gun loaded , flat in the mark on the table.
Start Position:	Standing inside the area , hands above the shoulders
Start:	audible signal.
Procedure:	At the start signal engage targets from within designated area with strong hand only . Note: IP activate s the target T3, which remains visible at rest.

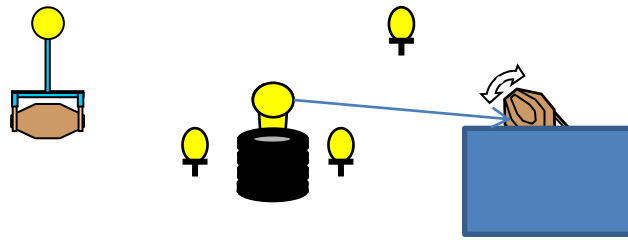

A

Stage:	04- HANDGUN
Targets:	2 IPSC Targets, 1 IPSC Popper and 4 IPSC Metal Plates.
Number of rounds to be scored:	9
Start Position:	Standing inside the area .
Start:	audible signal.
Procedure:	At the start signal engage targets from within designated area. Note: PL01 activate the Target 01 and Popper activates the target T2, both remain visible at rest.

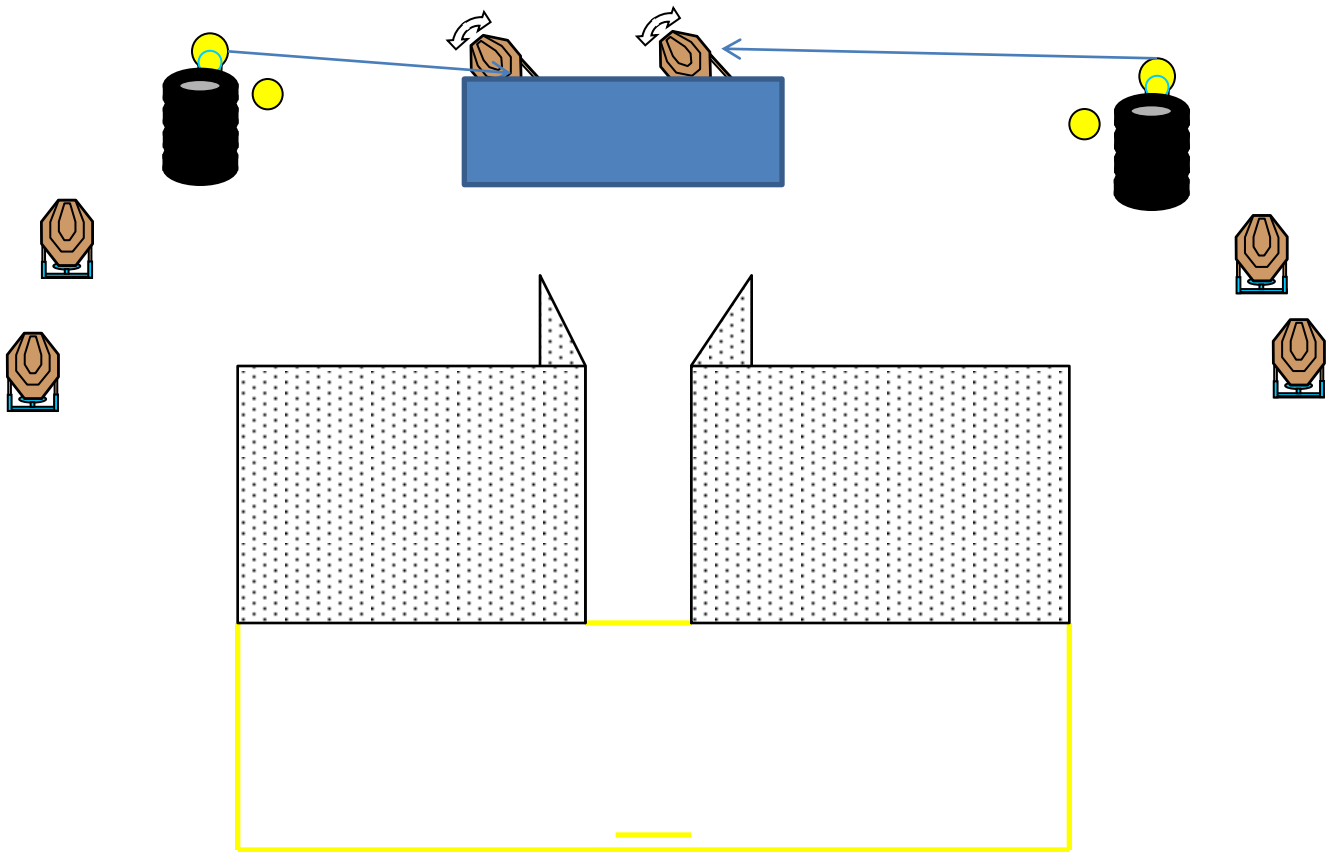

Stage:	05- HANDGUN
Targets:	4 IPSC Targets, 2 IPSC Popper and 2 IPSC Metal Plates.
Number of rounds to be scored:	16
Start Position:	Standing , heels touching the start line
Start:	audible signal.
Procedure:	At the start signal engage targets from within designated area.
Note:	The P1 activate s T2 and P2 activates T3, both targets remain visible at rest.

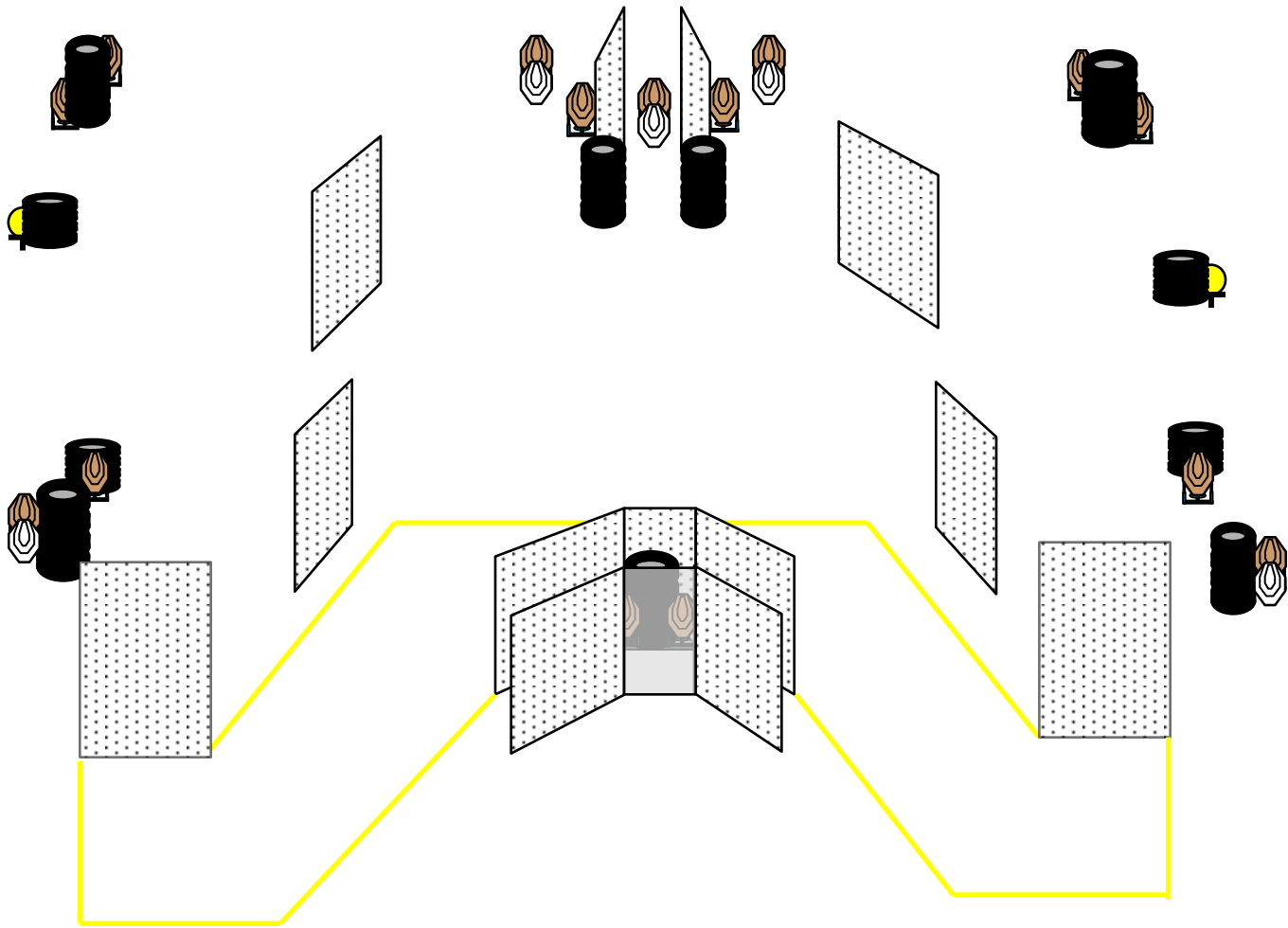

Stage:	06 HANDGUN
Targets:	15 IPSC Targets, and 2 IPSC Metal Plates.
Number of rounds to be scored:	32
Start Position:	Standing inside the area .
Start:	audible signal.
Procedure:	At the start signal engage targets from within designated area.

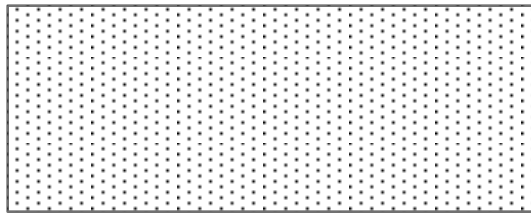
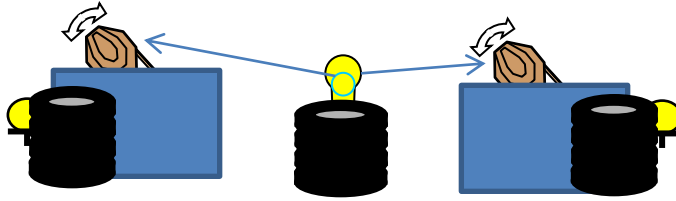

Stage:	07 - HANDGUN
Targets:	04 IPSC Targets, 1 IPSC Popper and 2 IPSC Metal plates.
Number of rounds to be scored:	11
Start Position:	Standing inside the area .
Start:	audible signal.
Procedure:	At the start signal engage targets from within designated area
Note:	The Popper P1 activate the Target T3 and T4, both remain visible at rest.

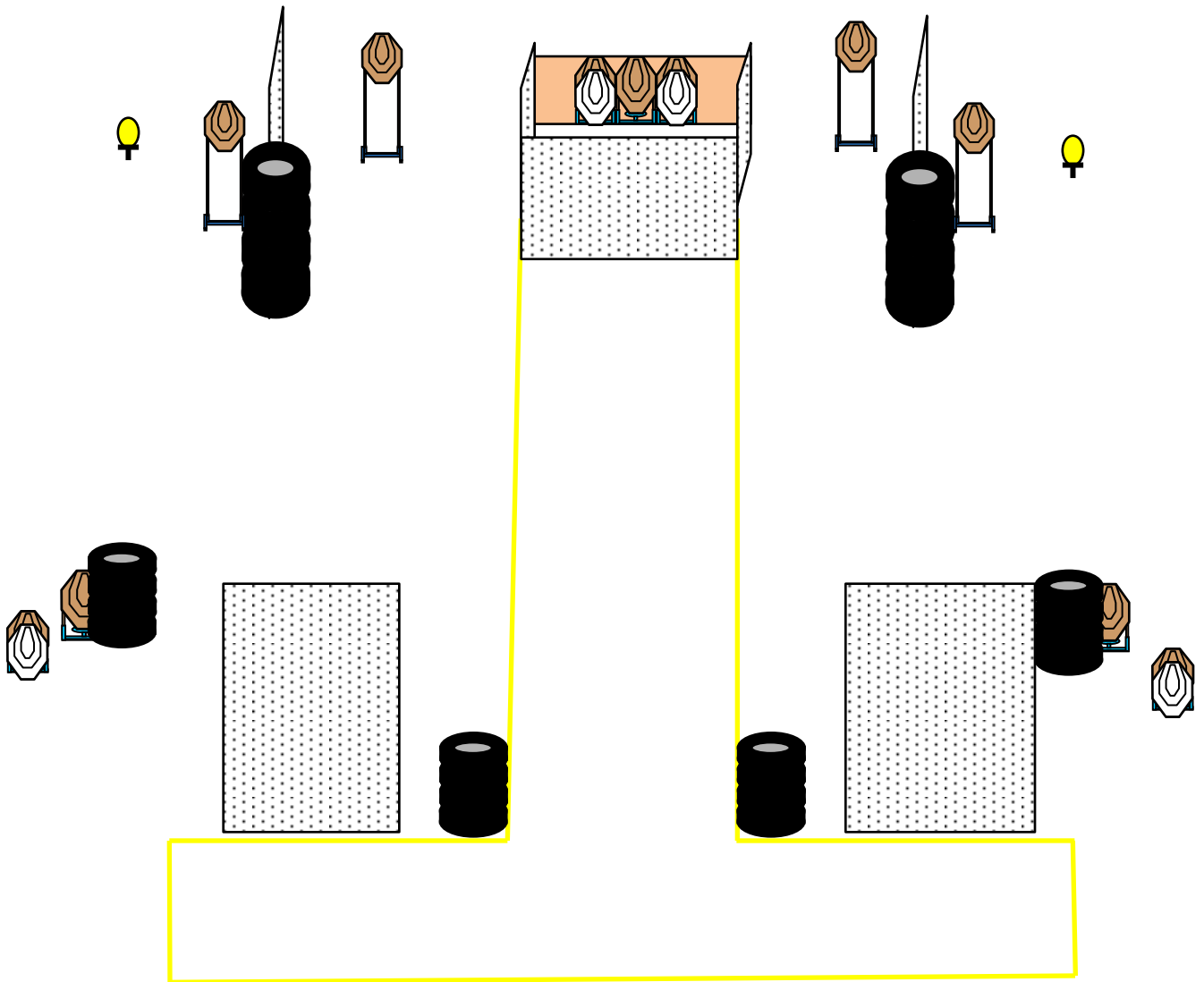

Stage:	08 - HANDGUN
Targets:	11 IPSC Targets and 2 IPSC Metal Plates.
Number of rounds to be scored:	24
Start Position:	Standing inside the area
Start:	audible signal.
Procedure:	At the start signal engage targets from within designated area.

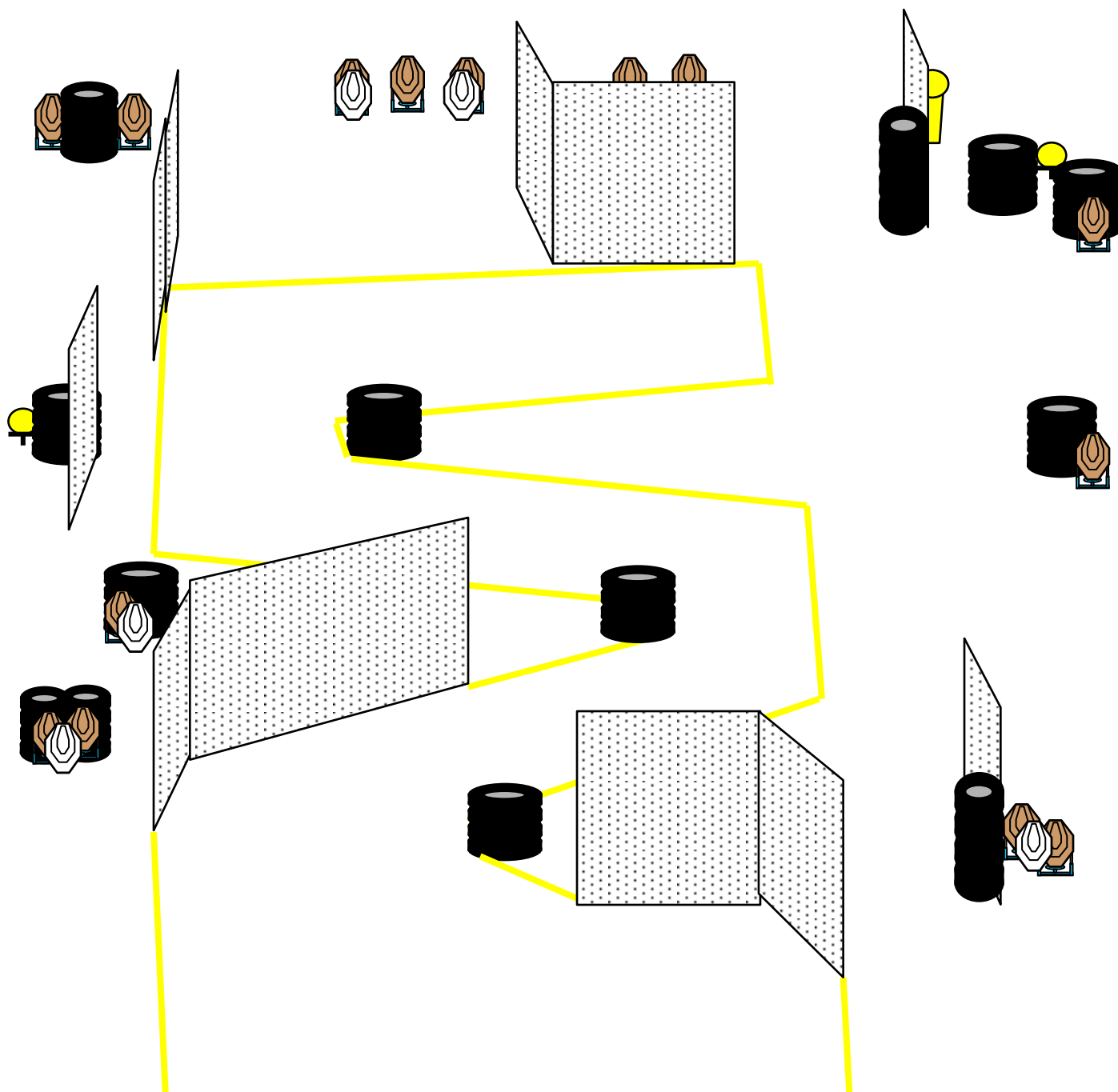

Stage:	10 - HANDGUN
Targets:	14 IPSC Targets, 1 IPSC Popper and 2 IPSC Metal Plates.
Number of rounds to be scored:	31
Start Position:	Standing inside the area .
Start:	audible signal.
Procedure:	At the start signal engage targets from within designated area

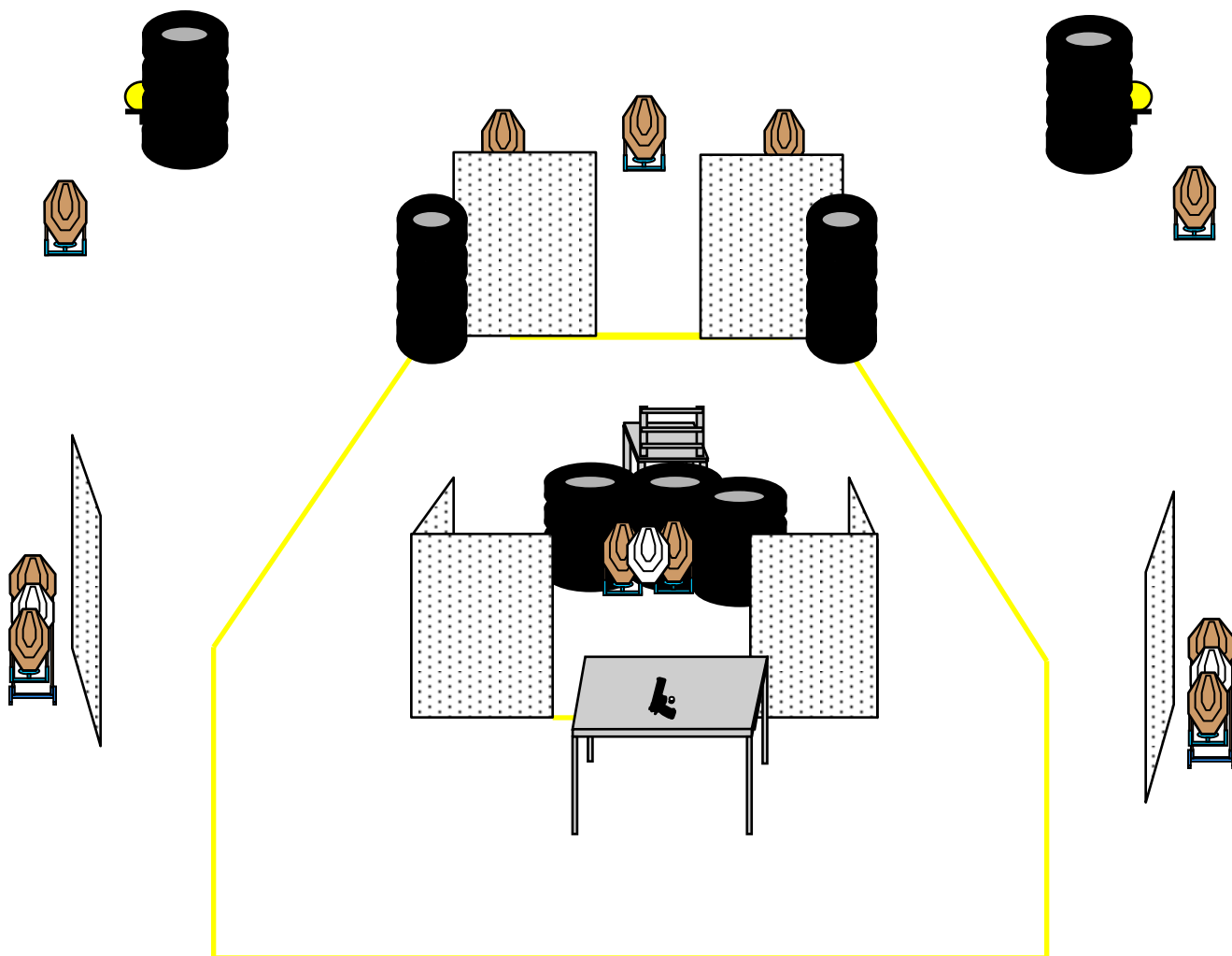

Stage:	11 HANDGUN
Targets:	11 IPSC Targets and 2 IPSC Metal Plates.
Number of rounds to be scored:	24
Gun ready condition:	Chamber and Magwell empty, flat in the mark on the table.
Start Position:	Sitting on the chair, feet on the marks and hands on the knees.
Start:	audible signal.
Procedure:	At the start signal engage targets from within designated area.

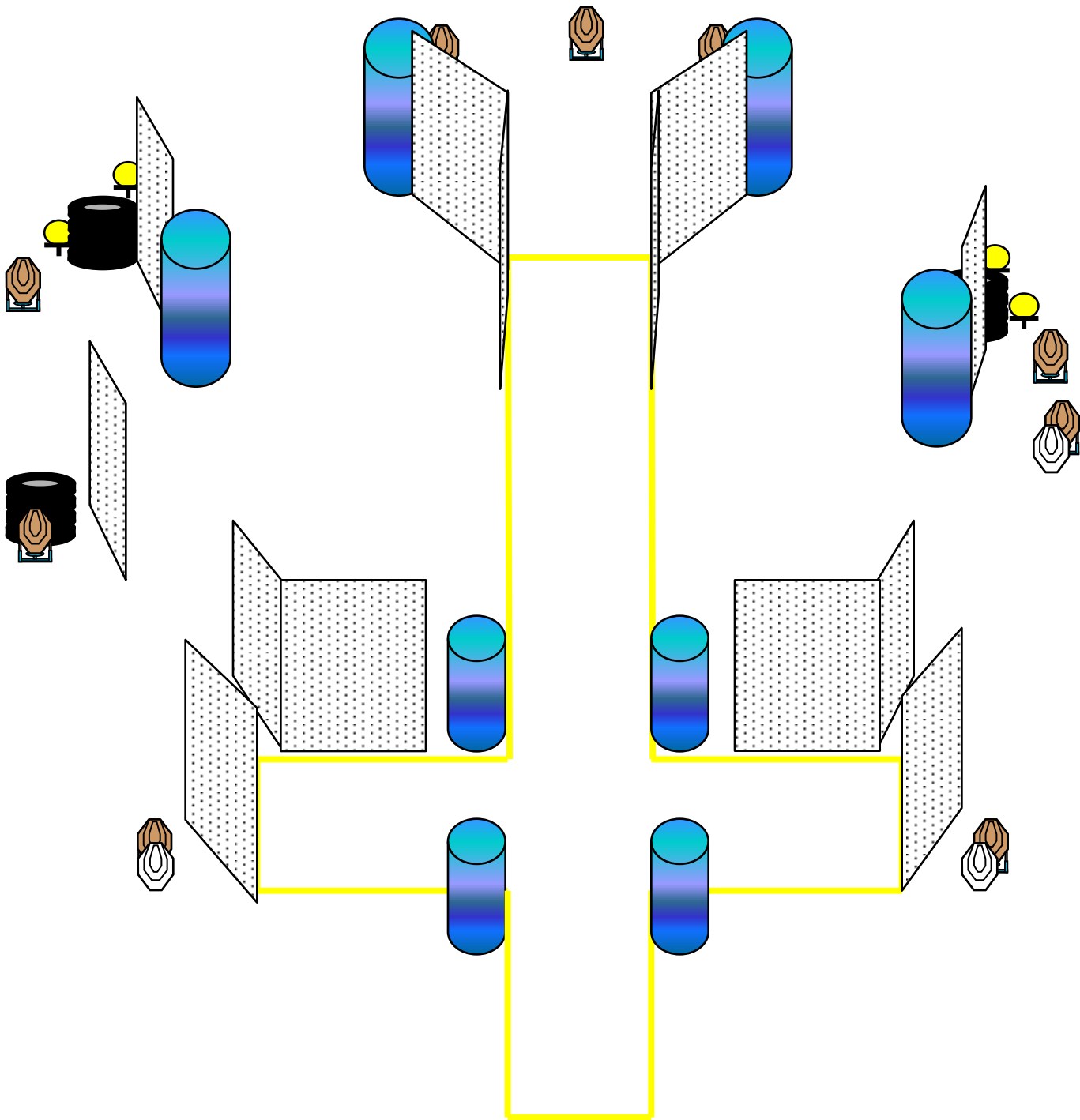

Stage:	12HANDGUN
Targets:	09 IPSC Targets, and 4 IPSC Metal Plates.
Number of rounds to be scored:	22
Start Position:	Standing inside the area .
Start:	audible signal.
Procedure:	At the start signal engage targets from within designated area.

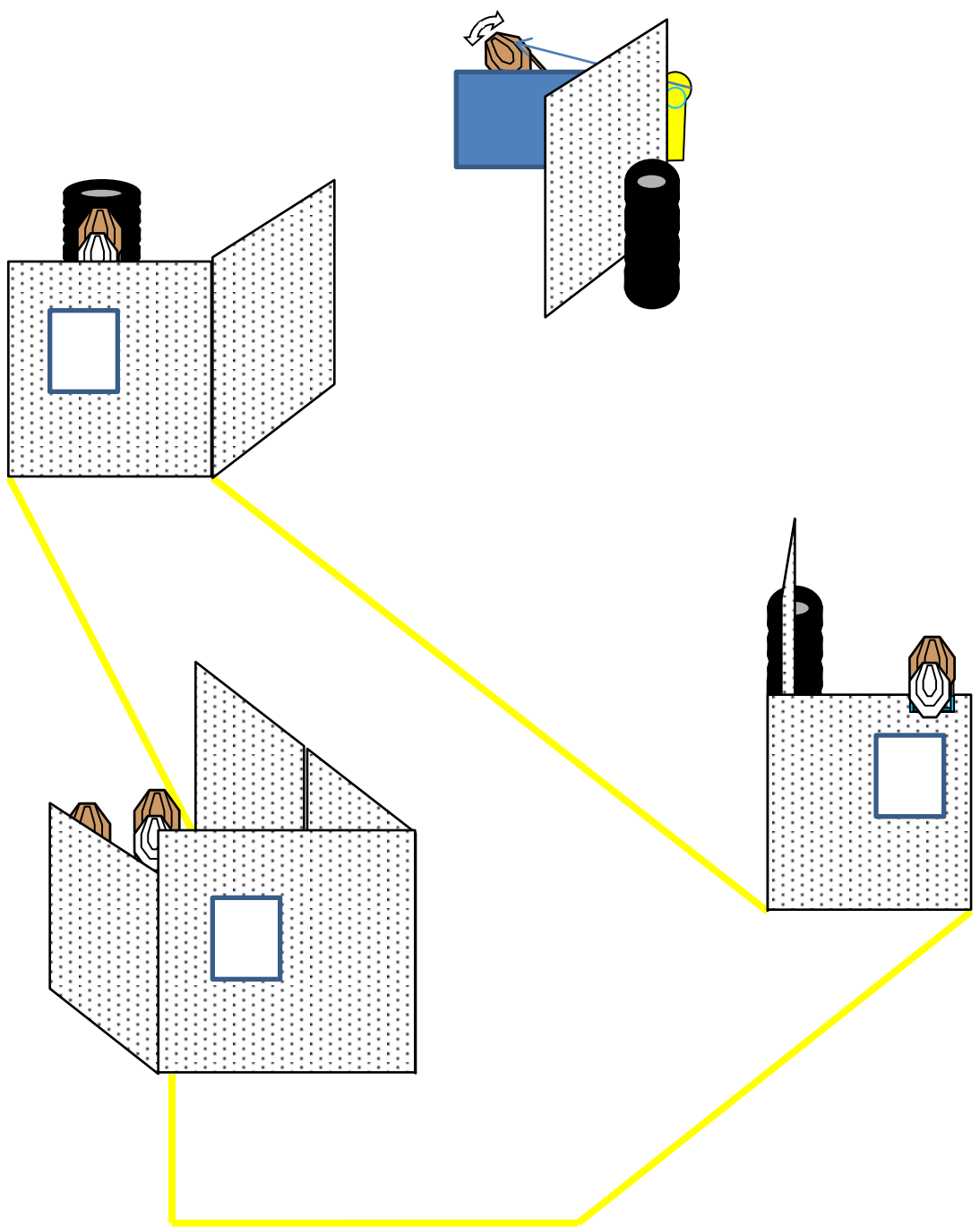

Stage:	13 - HANDGUN
Targets:	5 IPSC Targets and 1 IPSC Popper.
Number of rounds to be scored:	11
Start Position:	Standing inside the area .
Start:	audible signal.
Procedure:	At the start signal engage targets from within designated area .
Note:	The IP1 activate de Target 5 which remains visible at rest.

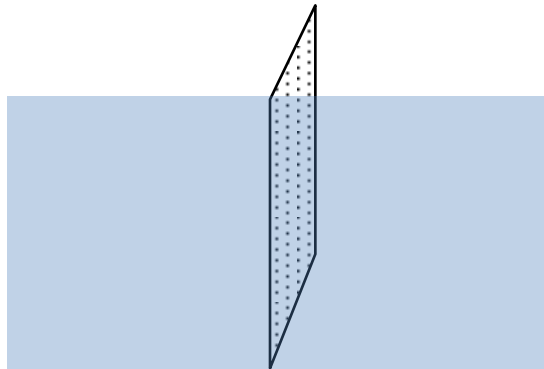
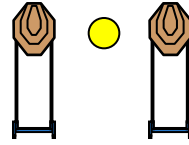
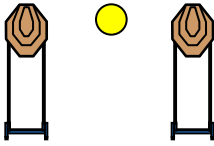

Stage:	14- HANDGUN
Targets:	4 IPSC Targets and 2 IPSC Metal Plates.
Number of rounds to be scored:	10
Start Position:	Standing inside an area holding the bag.
Start:	audible signal.
Procedure:	At the start signal engage targets from within designated area

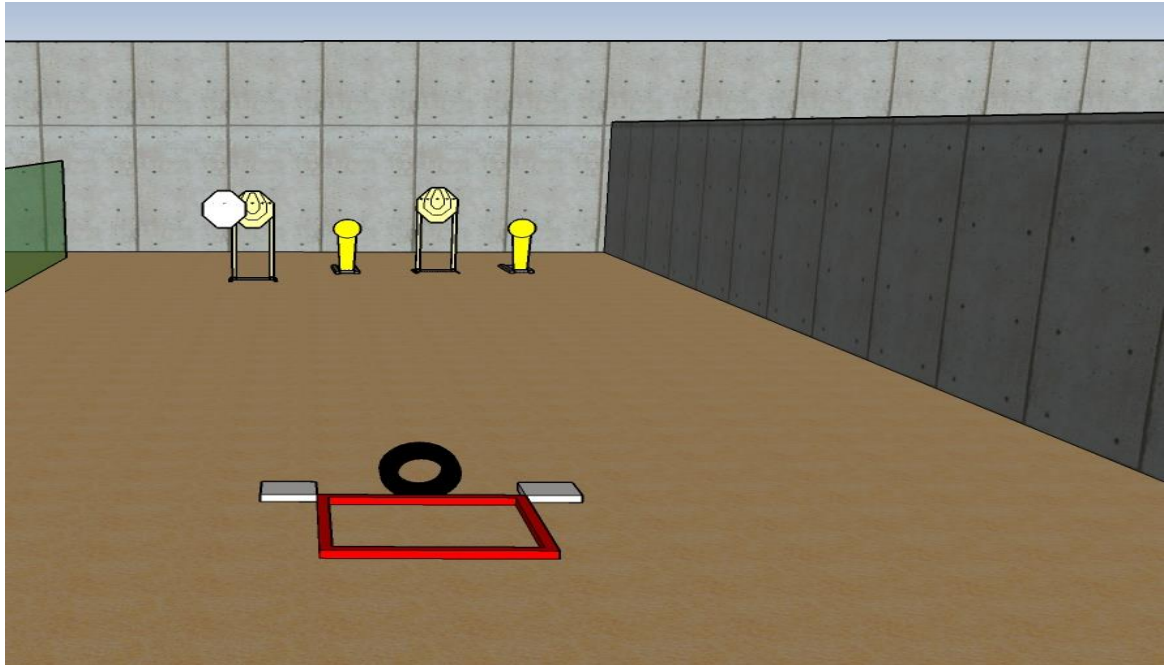

Stage:	15 - CLC 31
Targets:	2 IPSC Targets and 2 IPSC POPPERS.
Number of rounds to be scored:	6
Start Position:	KNEELING WITH AT LEAST ONE KNEE TOUCHING THE GROUND IN AREA 'A'. FACING DOWNRANGE WITH BOTH HANDS ON TOP OF A CAR TIRE WHICH IS STANDING UPRIGHT.
HANDGUN READY CONDITION	THE LOADED HANDGUN WILL BE PLACED ON A PAD ON THE GROUND ON EITHER SIDE OF THE TIRE.
Start:	audible signal.
Procedure:	AFTER THE AUDIBLE START SIGNAL, USING THE WEAK HAND ONLY, ENGAGE TARGETS, WEAK HAND ONLY, FROM WITHIN THE DESIGNATED

CLC 31 SETUP

IPSC Classifier

Stage: CLC-31

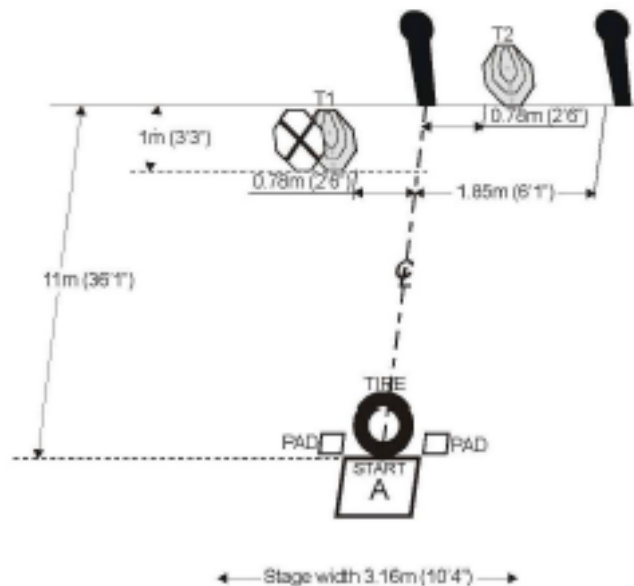

Type of Course:	Short Course
Targets (type & number):	2 IPSC Targets, 2 IPSC Popper, 1 No Shoot
No. of rounds to be scored:	6
Maximum points:	30
Start position:	Kneeling with at least one knee touching the ground in area 'A'. Facing downrange with both hands on top of a car tire which is standing upright.
Handgun ready condition:	The loaded handgun will be placed on a pad on the ground on either side of the tire. The handgun is pointing downrange.
Procedure:	After the audible start signal, using the weak hand only, engage targets, weak hand only, from within the designated area 'A'.
Setup Notes:	Set IPSC Targets/No Shoot to 1.52m (5') to the top of the targets. Area 'A' is 0.92m (3') by 0.92m (3'). The car tire is not rimmed and is from a minimum of 14 inches rim.

IPSC HANDGUN

PISTA	TARGETS	POPPER	PLATE	TOTAL DISPAROS
1	12			24
2		1	7	8
3	3	1	2	9
4	2	1	4	9
5	4	2	2	12
6	15		2	32
7	4	1	2	11
8	11		2	24
9	5		2	12
10	14	1	2	31
11	11		2	24
12	9		4	22
13	5	1		11
14	4		2	10
15	2	2		6